

Automated Optical Assembly

R. Hill, C. Skellett and D. Bremner [BAE SYSTEMS]

Abstract: While the optical design of optoelectronic packages is usually straightforward, achieving high yield involves detailed investigation of the sensitivities of the coupling to positional errors, temperature and other factors causing distortion. We have designed a modulated laser with fibre output for use in an aircraft environment. The coupling optics are welded for stability and adjusting an additional lens compensates the inevitable Post-Weld Shift. This results in a high alignment yield.

In attempting to automate assembly, new manufacturing processes and a robust alignment strategy must also be developed. Several alignment strategies have been tested. Our assembly robot uses a straightforward simplex algorithm, which adjusts two lenses iteratively. The P-WS compensating lenses are added by offsetting the focusing lens in the collimated beam path by a pre-determined distance. This strategy relies on the reproducibility of the focal length of these lenses.

INTRODUCTION

The assembly of optical hybrids demands sub-micron tolerances. In all cases it is best to seek a passive alignment approach to simplify assembly. However, there are many situations where active alignment is necessary.

Automation should be considered for all designs as this imposes discipline on the engineer and encourages the development of good tooling and planning. Again there are situations where the product volume or the lack of skilled operators means that the cost and timescale of automation can be justified.

This paper describes the development of an automated assembly facility for the manufacture of a fibre-optic modulator hybrid. The output power is to be greater than 2mW at a wavelength of 1.53micron and modulated at rates of up to 40Gbit/sec. It is to operate at temperatures in the range -54 to +90degC and vibration levels reaching 100g rms at low frequencies.

The design was constrained by the commercial availability of suitable laser diodes, thermo-coolers and a modulator substrate. Lenses and lens holders were designed to provide optical coupling at low loss levels. Assembly processes were also developed in conjunction with Finite Element models to ensure that the environmental performance could be achieved.

The most significant design challenges were to achieve high yield levels in production and to develop an alignment strategy suitable for an automated machine.

OPTICAL DESIGN and SENSITIVITY ESTIMATES

The radiation from the laser diode is collimated and passed through an isolator. These components are mounted on a thermo-cooler. The collimated beam is focused onto the wave-guide input of the GaAs modulator substrate. Similarly, the output from the modulator is collimated and then focused onto the single mode output fibre.

Figure 1: Pro-Engineer drawing of the fibre-optic modulator.

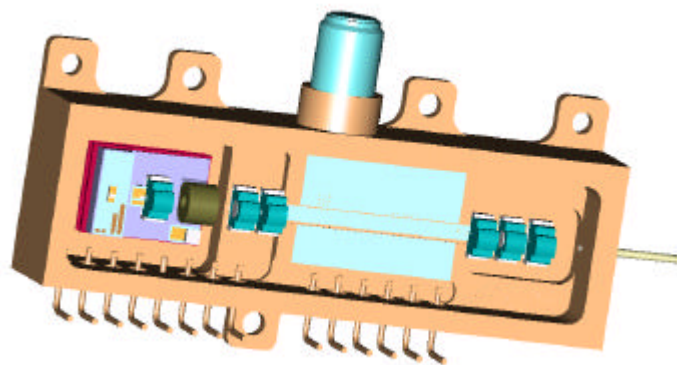

The minimum output power is to be 2mW at 1.53 micron and the modulator is capable of modulation at rates equivalent to 40Gbit/s.

Figure 2: Coupling optics design – optimisation and sensitivity.

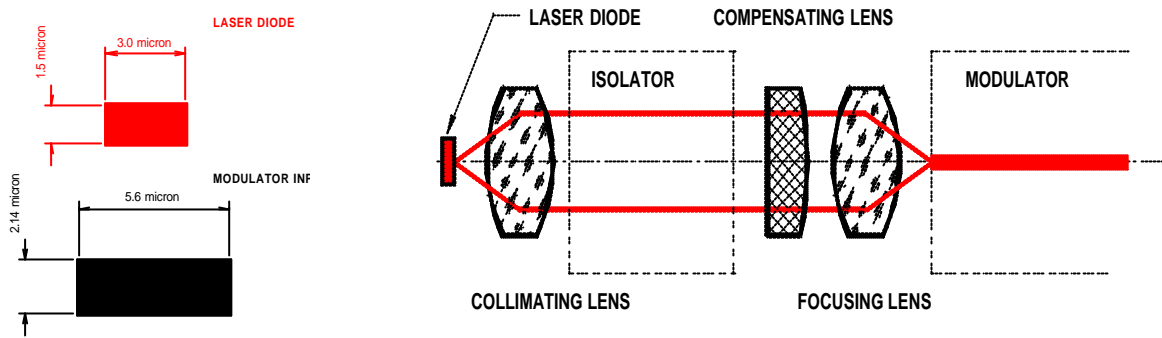

The laser diode output aperture is coupled by the collimator and focusing lenses to the input aperture of the wave-guide modulator. The coupling was calculated using the overlap integral method. The calculation method was extended [1] to include the coupling sensitivity to translation or rotation. This is illustrated by the graph showing how the coupling varies with the linear magnification afforded by the two lenses.

If the focusing lens before the modulator is moved by one micron in the X-direction (horizontal) then the coupling falls by about 15%. If, however, the lens is moved by one micron in the Y-direction (vertical) the coupling falls by 50%. This illustrates the major problem for the assembly of optoelectronic devices.

Coupling Efficiency as a Function of Magnification
Showing the Effect of a One Micron Shift of the Final Lens
in the X (red) - and Y (blue) - Directions

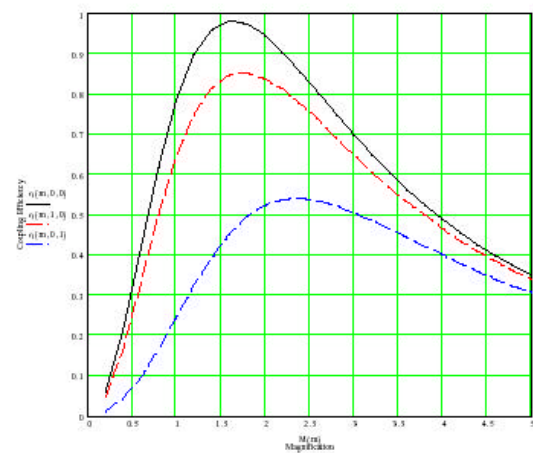

The optical design was evaluated using Code V. This enabled the effects of aberrations to be calculated in estimating the coupling losses - as well as calculating the sensitivities to translation or rotation of the lenses.

In order to check these results, the more important ones were reproduced using a matrix method suggested in the reference [2]. Plotting the results as 'ray diagrams' augmented this process.

Figure 3: Ray diagrams for the first optical 'module' – showing also the result about the focal point.

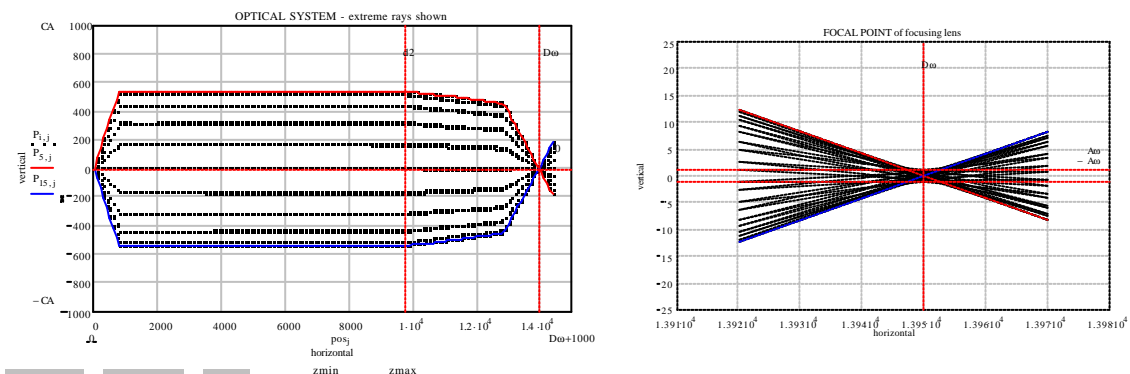

The positional sensitivity of each lens was calculated. The result was that, in most cases, a translation of one micron, or of 0.02 degree caused a coupling loss in the range 0.5 - 3.0 dB.

Coupling loss due to astigmatism did not exceed 1dB even in coupling the rectangular modulator waveguide to the circular fibre. An anamorphic lens was not required.

The dominant loss mechanism is not diffraction but spherical aberration. For this reason, aspheric lenses were designed. The potential loss due to aberrations was estimated using the method of Wagner and Tomlinson^[1]. They are shown as a function of wave front error in *figure 5*. A pk-pk wavefront error of 0.2 wavelengths causes a loss of about 0.5dB.

Figure 4: Summary diagram.

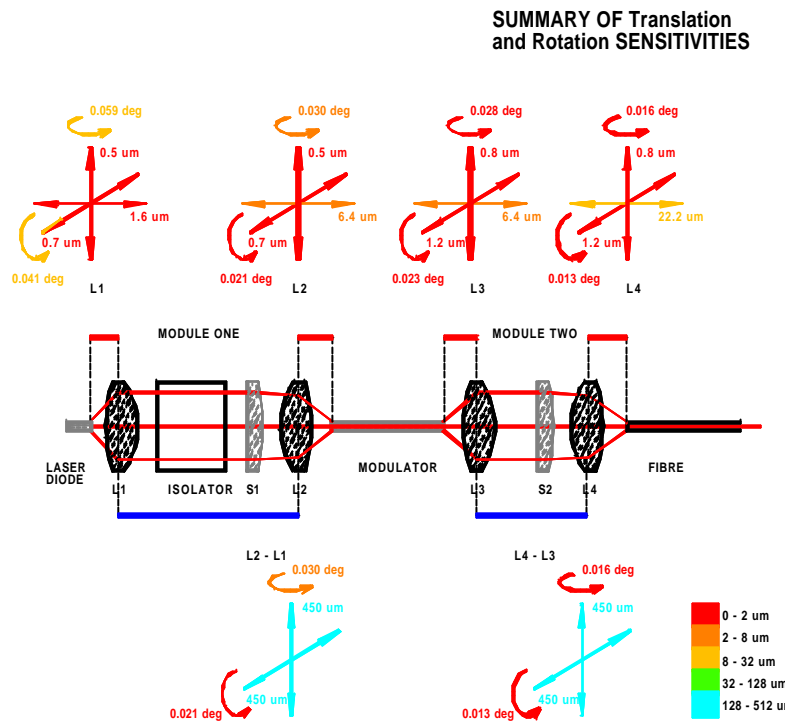
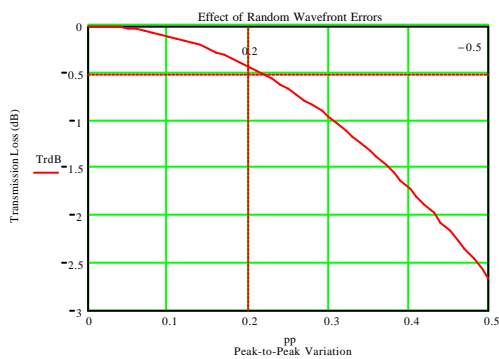

Figure 5: The effect of Wavefront Error.



THE LENS HOLDER and F.E. MODEL

The lenses were mounted in a stainless steel holder. This features notches by which it can be held by grippers – in case we decided to mount it on a deformable lens clip. This option was discarded due to concerns with the reliability and ease of adjustment of the technique. In addition, circumferential notches were machined. This enabled a ‘bar-coding’ of each lens so that the optical recognition software can check the lens type - and hence its focal length.

The lenses are held in simple ‘goal-post’ clips made from Kovar by spark-erosion.

When the best position of the lenses has been found by following a search pattern, the lens is forced into the base of the package. The Kovar clips are then welded at the base to the Kovar package. When the lens is then raised again to its optimum height, the lens and clip are welded at the top of the supports. The weld height is above the optic axis. This enables a bimetallic temperature compensation to be introduced.

Figure 6: The lens holder and mounting clip.

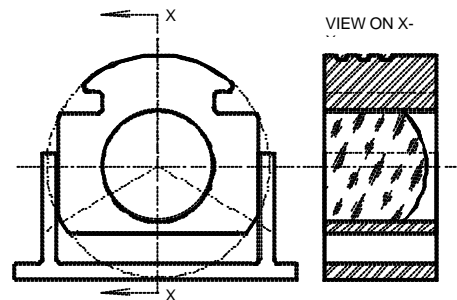

Design and drawing were carried out using ProEngineer. The drawings were the input into the IDEAS Finite Element modelling package. Distortion due to fixing screws, pressure change, temperature change and vibration were calculated. The largest changes, by an order of magnitude, were due to temperature variation.

Movement of the lenses was isolated as shown in *figure 8*. Vertical displacements appeared to come from a virtual origin at a point above the base plate. From this information, a spreadsheet was used to calculate the best height at which to weld the Kovar mounting clip to

Figure 7: Typical Finite Element Model printout

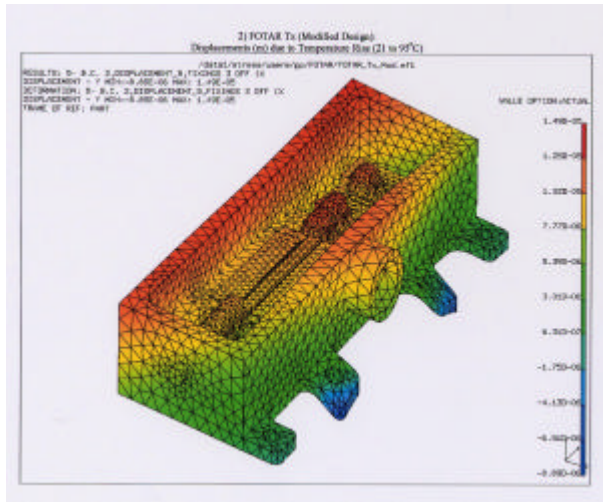
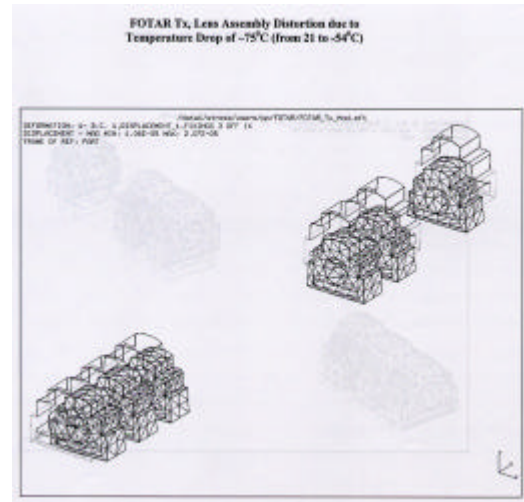

Figure 8: Movement of the Lenses.



the Stainless Steel lens holder for thermal compensation. For this method to be effective, both material specifications and machining and annealing processes have to be well controlled. Systematic displacement of the lenses due to temperature was compensated by the bimetallic principle. Different optimum weld heights are given for ‘optical module one’ between the laser diode and modulator, and ‘optical module two’ between the modulator and the fibre. The chosen value for the weld height was made closer to the optimum value for module one because of its greater positional sensitivity.

POST-WELD SHIFT (P-WS) and THE COMPENSATING LENS

Random displacement of the lenses due to positional and post-weld error has been estimated.

Figure 9: Coupling Variation with Vertical Position.

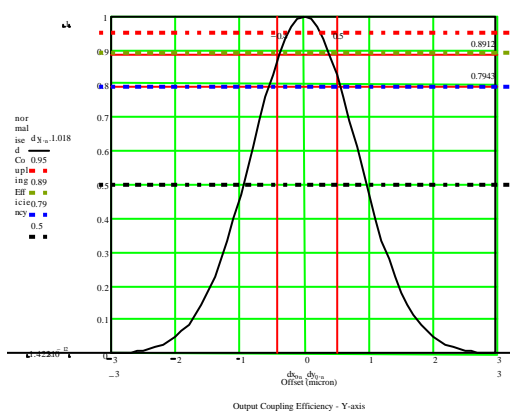
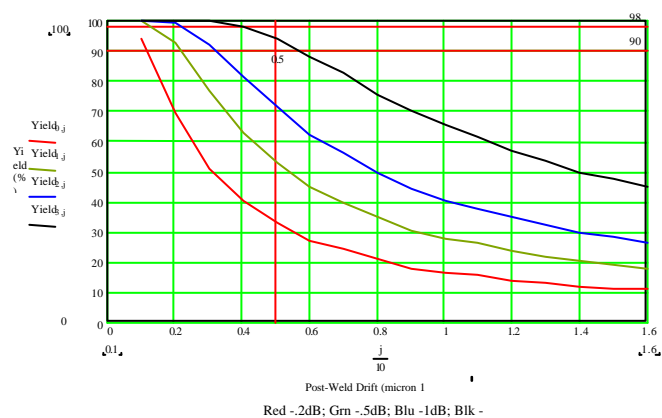

Figure 10: Yield Variation with P-WS



Assuming that the P-WS had a normal distribution, a Monte Carlo algorithm was used to plot the yield as a function of the one-sigma value of the P-WS. *Figure 9* shows how the coupling varies with position vertically. Also shown are the levels corresponding to coupling losses of -0.5 , -1 , -2 and -3 dB. The yield corresponding to each coupling level is shown in *figure 10* as a function of the P-WS. If an acceptable loss were -0.5 dB, then the yield for a P-WS of 0.5

micron one sigma would be 30%. Such a result is unacceptable. The components already fitted have a high cost and re-work is unlikely to be practicable.

What we need is either a method of ‘distorting’ the lens clips or a method of correcting for the positioning error, which results as the weld cools. It was proposed that an additional lens of long focal length compared to the focusing lens was to be fitted. This could be used to make a small correction for the position of the focal point. When welded, the resulting coupling loss due to P-WS is smaller because of its lower positional sensitivity. The yield improvement is shown in figure 12. The red line is the yield for -1dB coupling loss. The solid black line is for the adjustment of a compensating lens with a focal length $15.8x$ that of the adjacent focusing lens.

Figure 11: P-WS Compensating Lens.

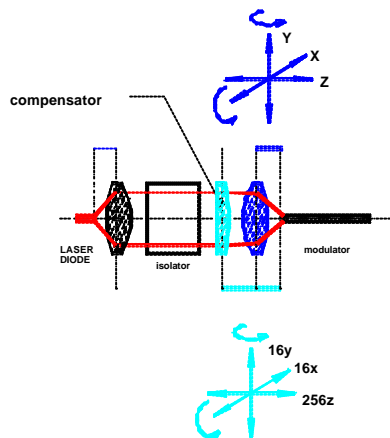
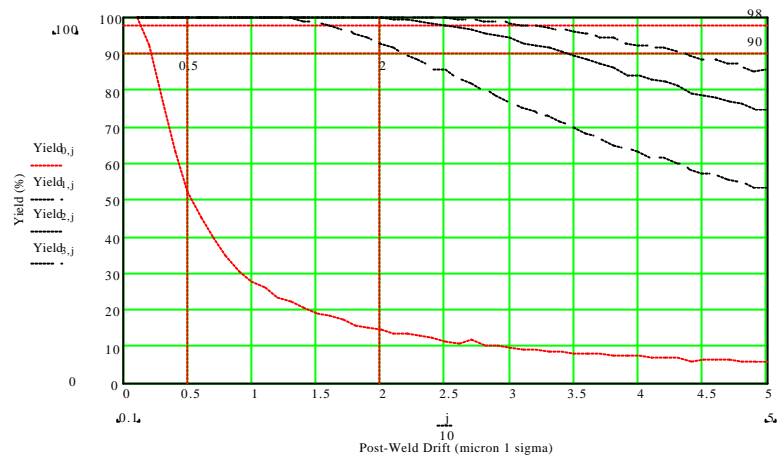

Figure 12: Yield Variation with P-WS



Red (no st. lens); x10; Blk (x15.8); x20

THE AUTOMATION CONCEPT

A specification was prepared for the manufacture of an assembly machine. It needed a positional accuracy of almost two orders of magnitude better than a ‘pick-and-place’ machine. The volume of the product is quite small, so the travel of the actuators is short. The machine was to be capable of soldering, welding and attachment by U-V curing epoxy. Also specified was the use of an infrared camera for detecting ‘first light’ when focusing on the modulator, and a lock-in amplifier for use with the detectors.

The development machine was fitted with two sets of actuators for the lens grippers. One was a six-axis stage capable of fast movement and the other was a four-axis stage providing considerable force as well as positional accuracy. These features proved most useful at later stages in the development because there was enough confidence generated to attempt to adjust two lenses simultaneously. This proved feasible.

Figure 13: Package on Kinematic mount.

In the chosen concept, the package was mounted on top of a kinematic mount, which also had a connector providing all the necessary electrical connections and heating or cooling devices. Lens, isolators or other components required are stored in trays or gel-packs to the side of the machine. They are placed in the package by a pick-and-place arm. Identification of the components and control of the grippers is achieved using visual recognition software.

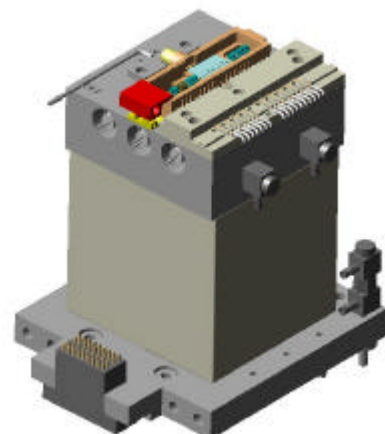

The 'flex-auto' software package was sufficiently flexible to allow programming by inexperienced operators. Software modules handle search algorithms and the control of specific components of the machine. In the event of failure of any particular operation or process, the operator can intervene or revert to a 'manual' mode.

Figure 14: Principal Features of the Assembly Machine.

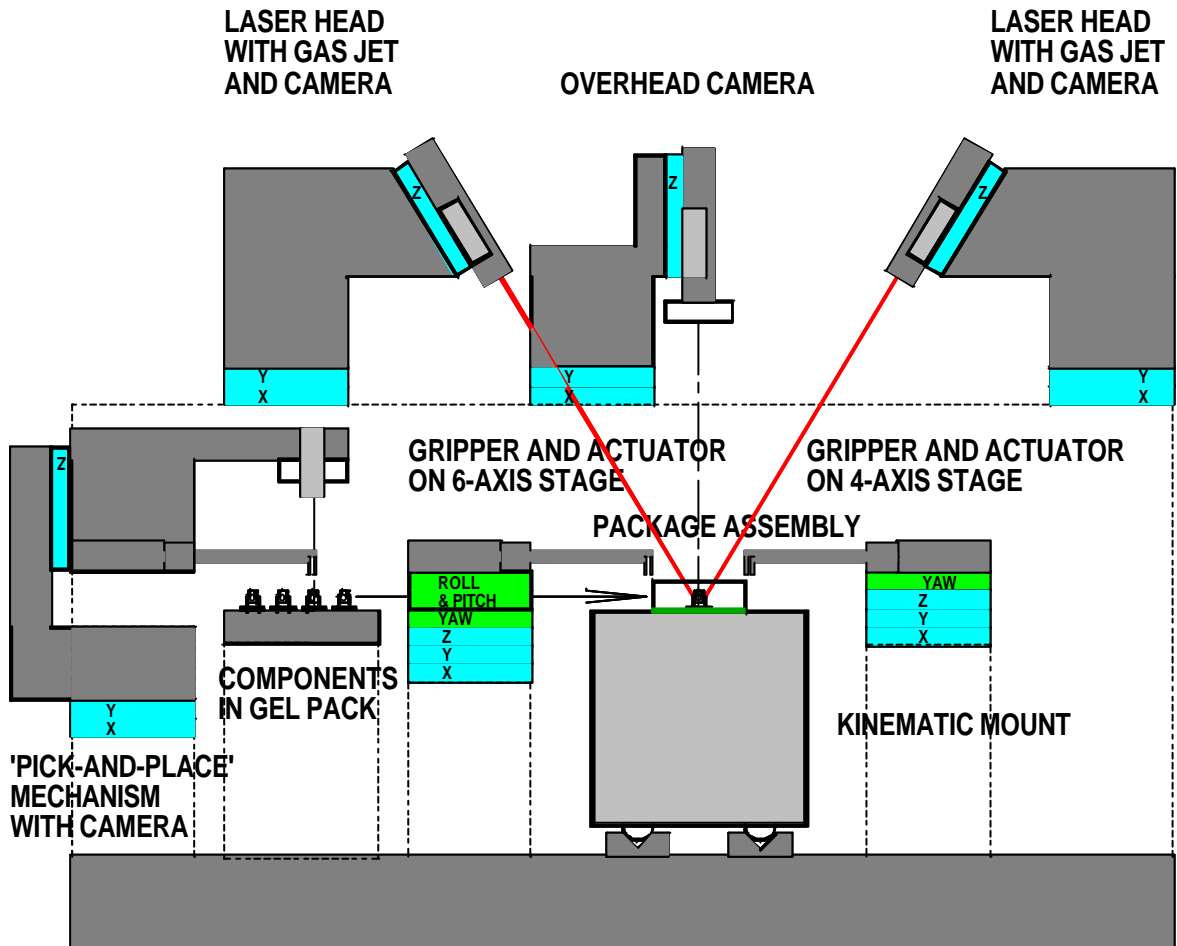

Figure 15: General View.



Figure 16: Operator Control Panel.



ALIGNMENT OPTIONS

Assuming that alignment is carried out on one lens at a time, alignment of the collimating lens can be achieved by -

1. Using a beam-splitter, imaging fibre bundle and I.R. camera. [Too much speckle].
2. Using a shear plate or confocal detector. [Not tried].
3. Focusing the beam onto the modulator input, then moving the lens toward the laser by a pre-determined distance. [Feasible, but sometimes it proved difficult to interpret the detector outputs].
4. Focusing the beam onto the modulator input and observing the 'sunrise' effect with the I.R. camera at the other end of the substrate. [Not easy to automate].

Having adjusted and welded the collimating lens, adjust the focusing lens by: -

5. Focusing the beam onto the modulator input. [Satisfactory].
6. Inserting a confocal microscope in the collimated beam path and trying to locate the input facet of the modulator substrate. [Not tried].

At this point, we have to decide how to fit the additional compensating lens. The options are -

7. Move the focusing lens toward the modulator by a pre-determined distance and insert the compensating lens. Adjust both for focus at the modulator input. Weld the focusing lens then adjust and weld the compensating lens. [Satisfactory but requires two grippers].
8. Move the focusing lens toward the modulator by a pre-determined distance and weld it in place. Add the compensating lens, adjust it and weld it in place. [Satisfactory but relies on the reproducibility of focal length of the focusing lens].

The best combination of adjustments was found to be 3, 5 and 8. However, it was found that the adjustments were quicker if both the collimating and focusing lenses were held in the two grippers and adjusted iteratively. This process replaces steps 3 and 5. The reduction in time taken for this alignment was at least a factor of three.

SUMMARY

Optical assemblies often require manufacture to sub-micron tolerances. The Post-Weld Shift of the lenses can dominate yield after alignment. Despite the additional cost, a compensating lens has been added and has proved satisfactory in increasing the yield to an acceptable level. In automating the alignment process, a strategy has to be developed which requires no operator intervention or decision. By adjusting the position of the collimating and focusing lens iteratively with a two-gripper robotic machine, this criterion has been realised. The change in the position of the focal point on adding the P-WS compensating lens has been corrected by a simple offset of the focusing lens position.

Acknowledgements

Colin Lemming, Precision Optical Engineering Ltd., England, modelled the optical design (and its many variants!) and estimated the effects of aberrations using 'Code V' software.

Louis Sander, Anteryon B.V., Holland, designed the lenses.

Automation Engineering Inc., USA, was responsible for the automation concepts, machine and control system design and software. Their assistance and cooperation in developing the manufacturing and alignment processes has been of inestimable value.

References

1. R.E. Wagner and W.J. Tomlinson, Coupling efficiency of optics in single-mode fiber components. Appl. Opt. V.21, No.5,p2671-2688 (1982).
2. A. Gerrard and J.M. Burch, Introduction to Matrix Methods in Optics. J. Wiley & Sons (1975), Appendix B, p286-291.